

DATE: June 13, 1988

FMEA #: 46-S70-0778-02-TP\*-01

END ITEM EFFECTIVITY:  
X X X  
OV102 OV103 OV104

MODEL NO/NAME: S70-0778, APU QD/Filter Set

ORBITER SUBSYSTEM: APU System QTY: 3

PART NUMBER:	PART NAME:	REFERENCE DESIGNATION:
5202-04AH-E12	Coupling	* TP16, 26, 36

CRITICALITY NUMBER: 2

FUNCTION: Connect to orbiter APU for fuel pump seal cavity alcohol purge.

CRITICAL FAILURE MODE: External leakage.

CAUSE: Seal failure, spring failure.

FAILURE EFFECT ON:

- (A) END ITEM: None; servicing halted, emergency precautions initiated.
- (B) INTERFACING SUBSYSTEM(S): None; fluid lines must be drained.
- (C) ORBITER: Possible damage to orbiter internal aft fuselage components from leaking alcohol or fire hazard.
- (D) PERSONNEL: Hazard to personnel from leaking alcohol fluid and fire hazard.

HAZARDS: Escape of alcohol, possibility of fire.

DATE: June 13, 1988

### ACCEPTANCE RATIONALE

**DESIGN:** Coupling is composed of corrosion-resistant steel, with ethylene propylene main O-ring seal and teflon backup seal and stop seal. Krytox 240AC is used as a lubricant (ground half only).

Manual connection utilizes an exterior lever, with spring-force release. Coupling is small, lightweight, and designed to minimize pressure drop. A detent prevents foreign object damage, and end fittings are free to swivel, preventing torque from being applied, and allowing easy alignment. The coupling meets the requirements of AIR1616 and MIL-STD-1290.

**TEST:**

**DESIGN VERIFICATION:** Testing is performed by the vendor, Symetrics, per part specification. Tests include working, proof, and burst pressures, engagement/disengagement cycling; leakage; pressure drop; vibration.

**PRE-OPERATIONAL:** Annual preventive maintenance per OMI V6A25 prior to use includes checks for missing parts; identification; cracks, corrosion, or deformation; proof pressure tags; fluid leakage; and general cleanliness. The APU system leak and functional test is performed per V1019.

**INSPECTION:** Receiving inspection is performed for all couplings. Couplings undergo receiving inspection for cleanliness, identification, corrosion protection and damage. Cleanliness during assembly is per MA0110-311, verified by inspection, sealing surface is inspected for damage prior to final assembly.

**OPERATIONAL USE:** Isolation of individual QD using GSE alcohol purge unit manual valves, draining of line per V1196. This also includes the use of an aspirator to provide suction, and instructions for spill containment, cleanup, and verification of airborne coupling closure.

**FAILURE HISTORY:** No failures have been recorded against this part in the PRACA system.

END ITEM MODEL #S70-0778 DESCRIPTION

The Auxiliary Power Unit (APU) Servicing Panel Quick Disconnect (QD)/Filter Set (Model #S70-0778) consists of ten unique QD/Filter assemblies which connect directly to the APU's, to the APU Water Systems and to the APU Servicing Panels on the orbiter skin using the left and right APU Ground Umbilical Carrier Plates (S70-0757 and -0758, respectively, Figure 3 - 1). The QD/Filter assemblies consist of couplings, filters, fittings and seals, along with caps and identification tags. The filters trap solid particles of 25 microns or larger in fluid with a temperature range of 65 - 120°F. Fuel loading is performed at the launch pad; postflight deservicing, including GN2, GHe, and alcohol purge, is performed at the Orbiter Processing Facility.

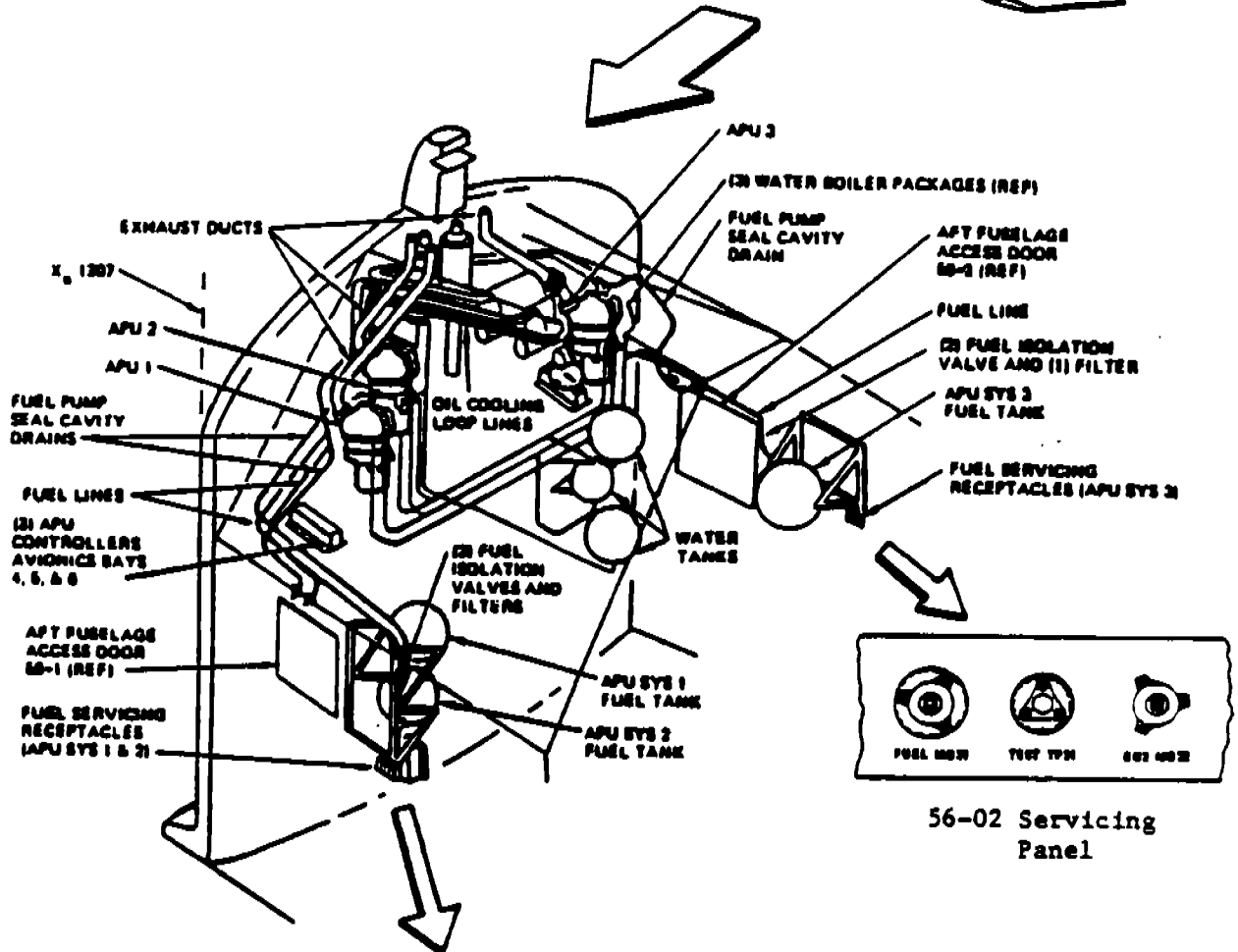
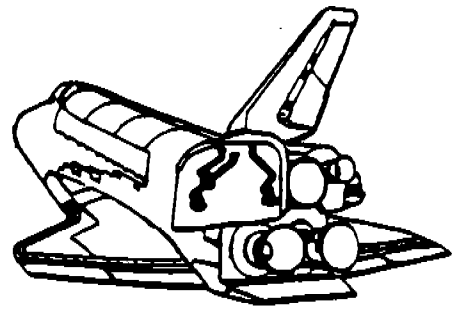

56-02 Servicing Panel

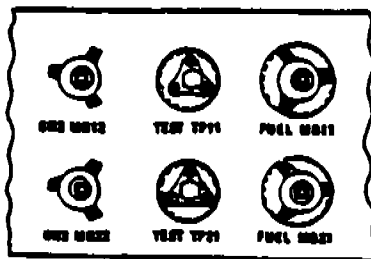

56-01 Servicing Panel

APU System Location, Components, Connections

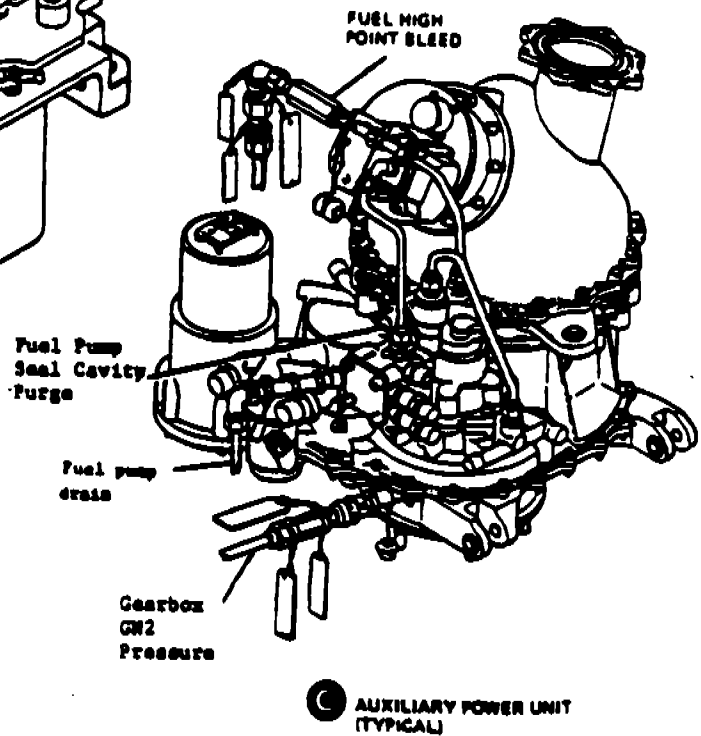
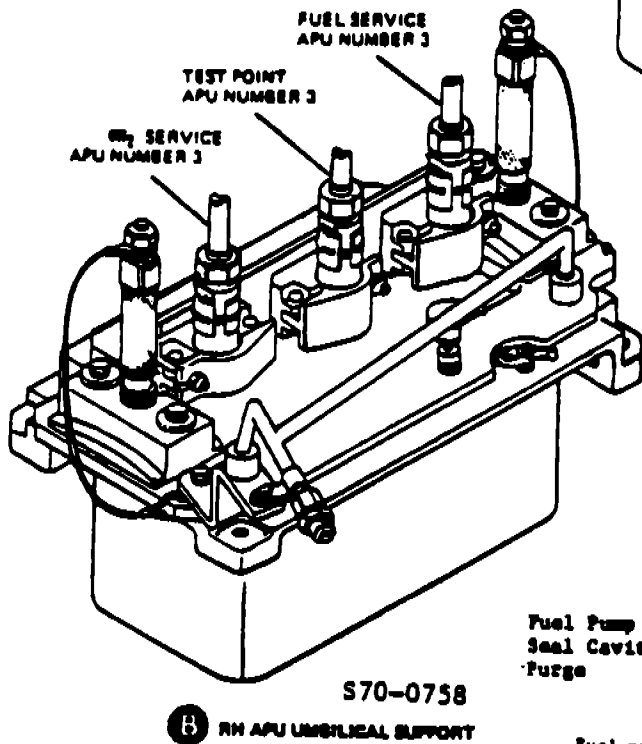
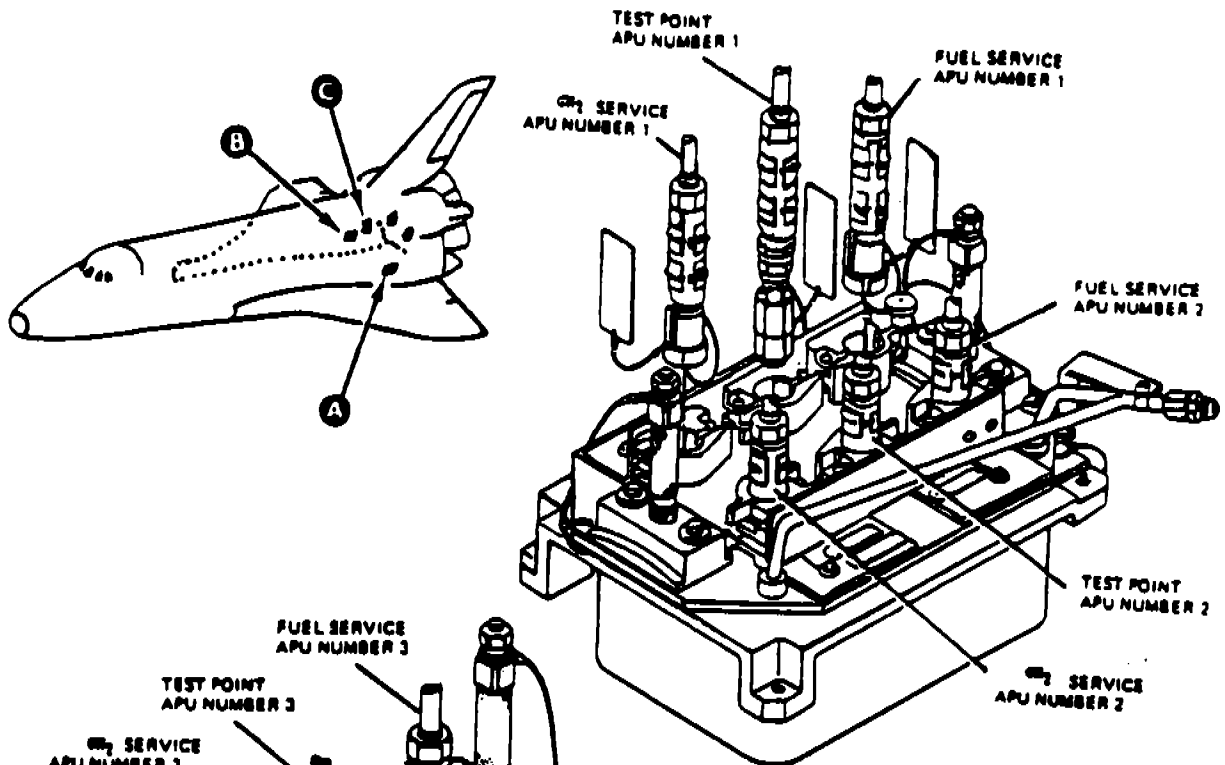

APU QD/Filter Set Connections

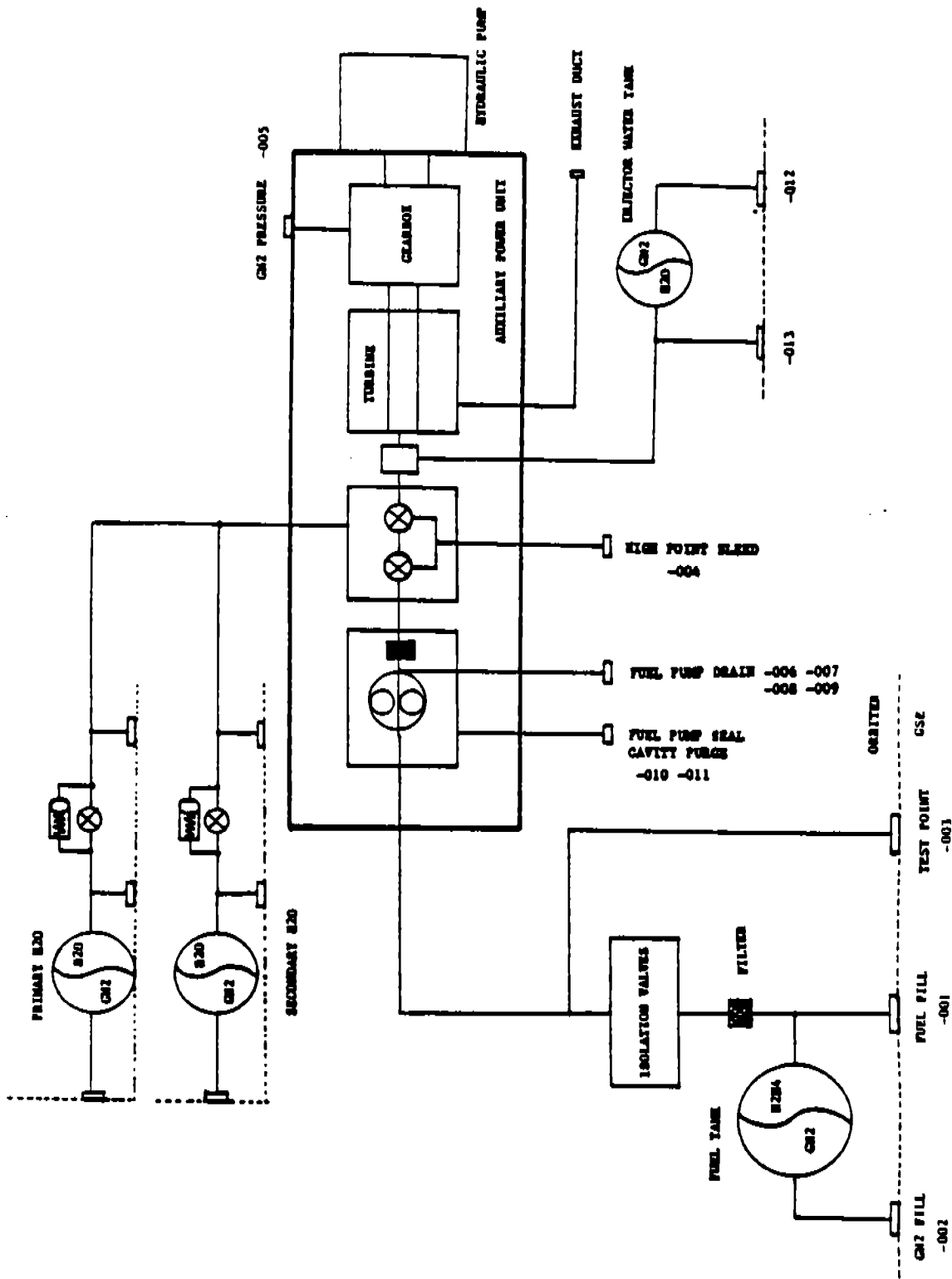

APU Fuel/gas System Block Diagram

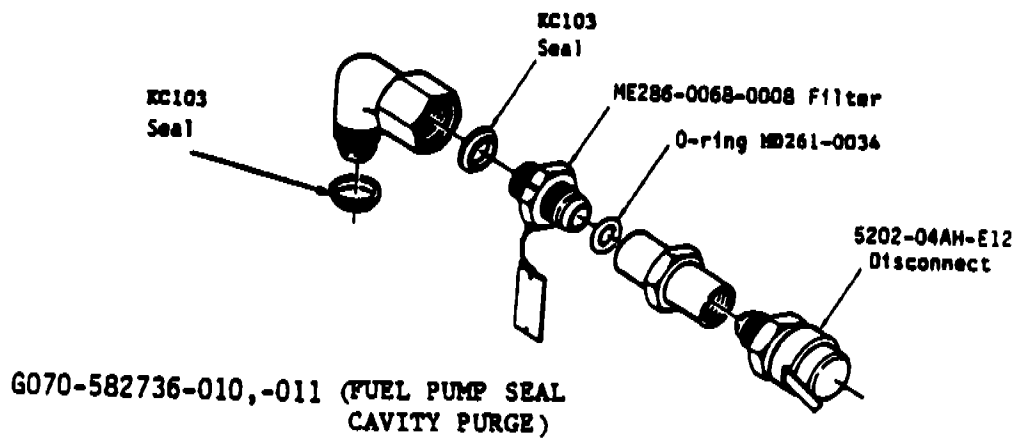
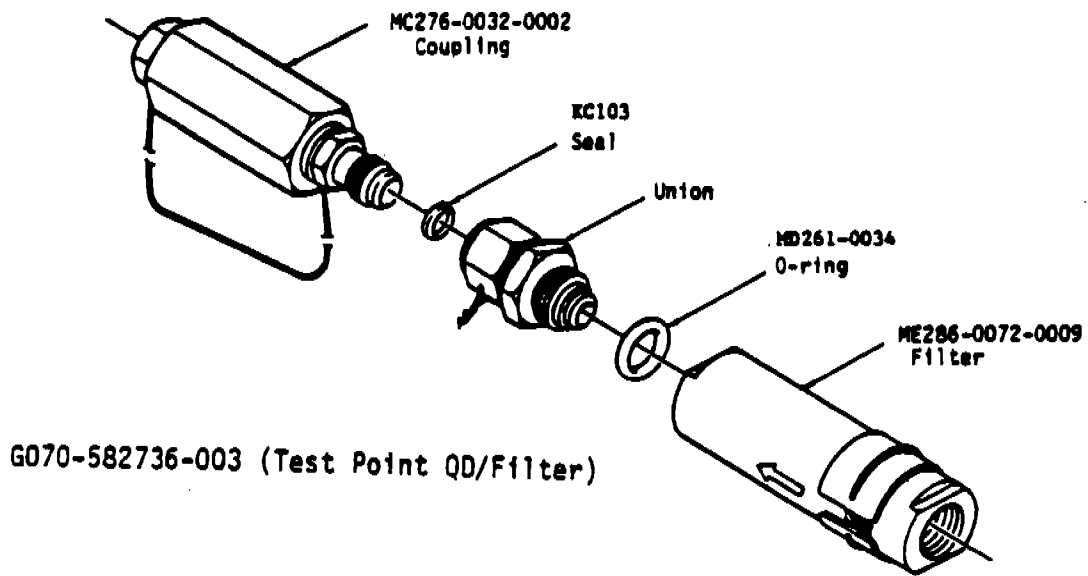
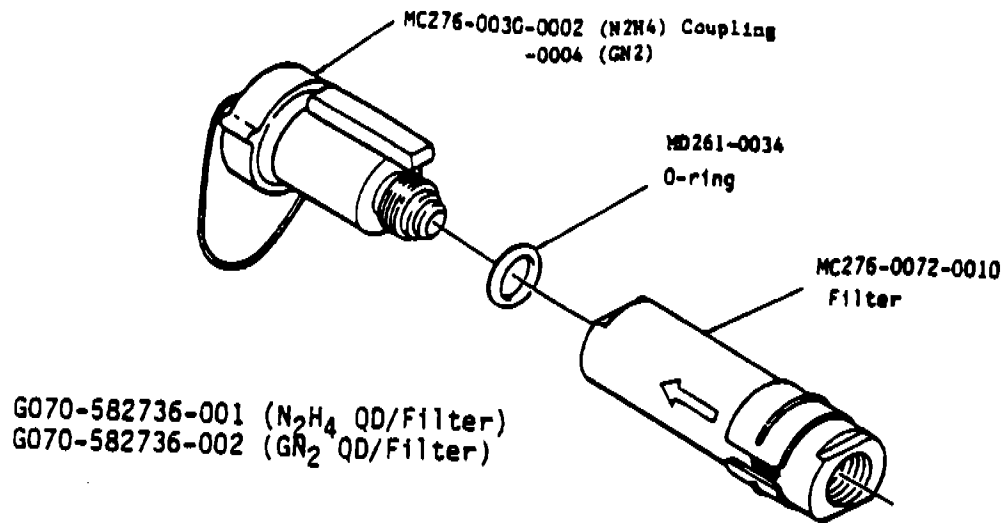

APU QD/Filter Set Components

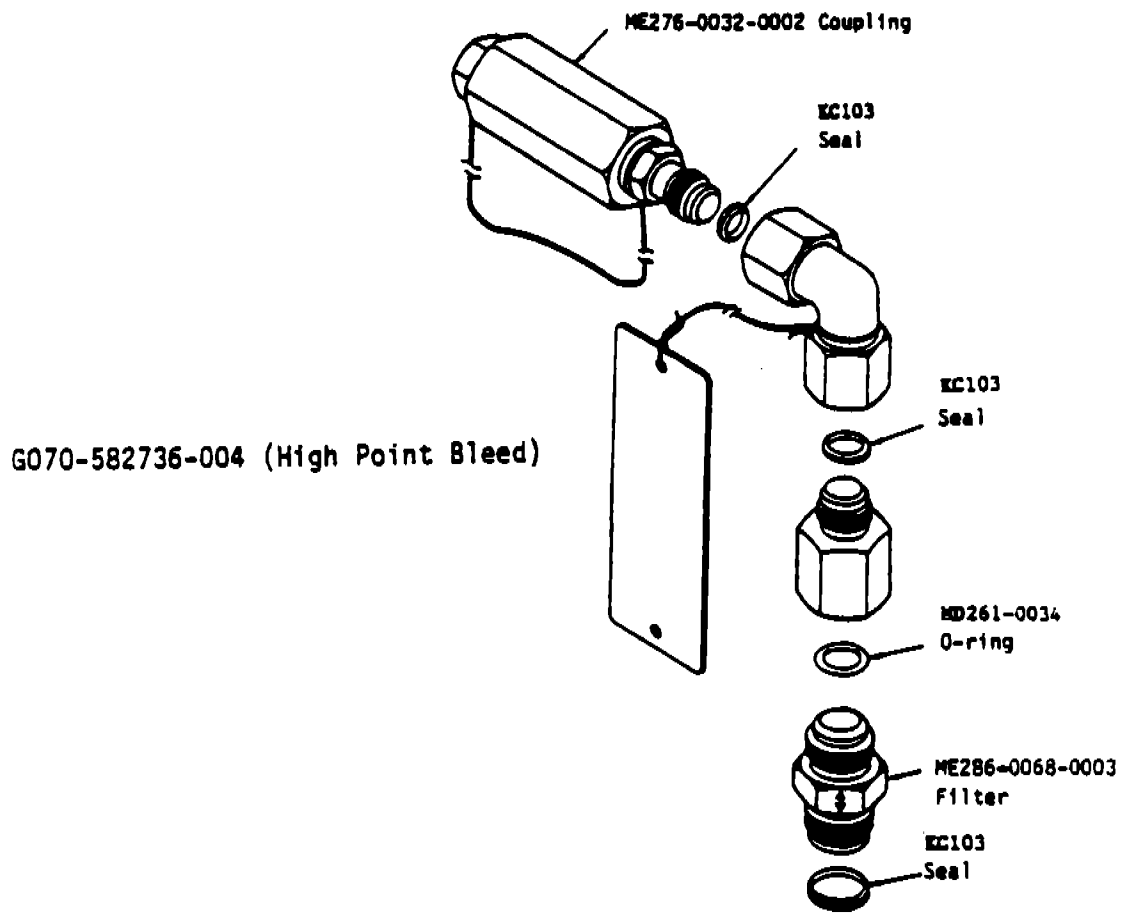
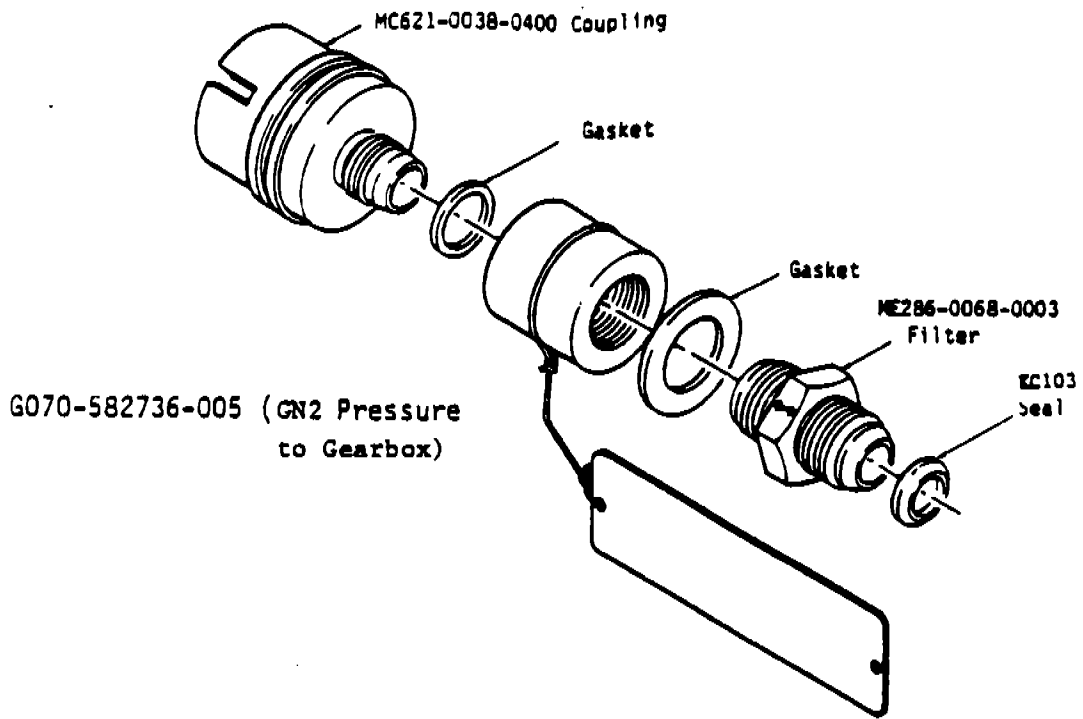

APU QD/Filter Set Components  
(cont'd)



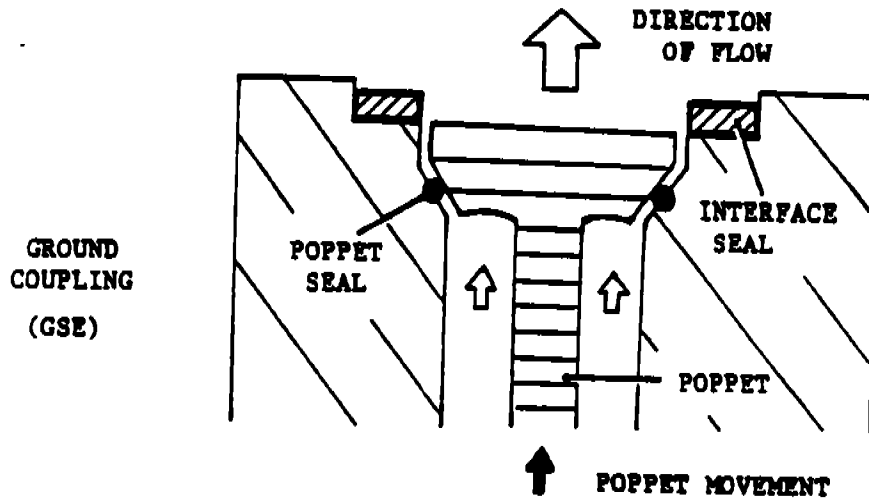
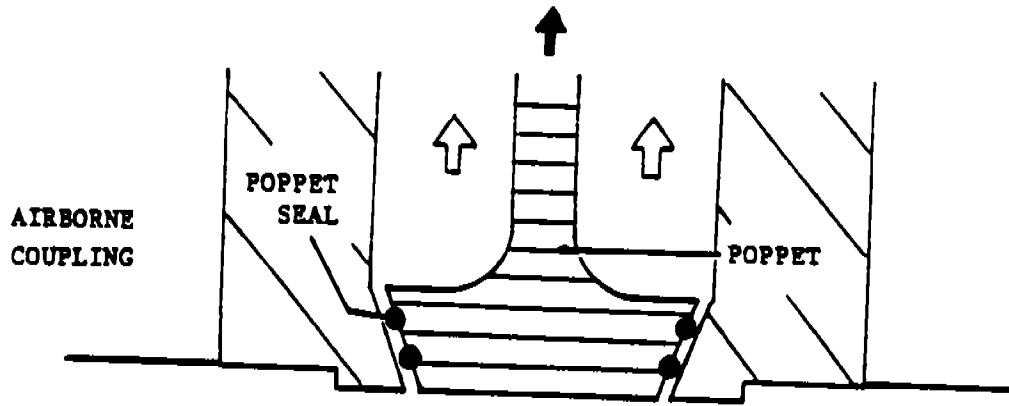

Typical Mating Connections